

Frigidaire

Factory Parts Catalog

Product No.	FCCS151FW0
Series	Commercial
Color	white
Volts	115
Owner's Guide	297068500
Market	North America
Energy Guide	216794214

 **Electrolux**

Electrolux Major Appliances
North & Latin America
P.O. BOX 212378
AUGUSTA, GA 30917

Publication No.
5995460028
06/02/01
(EN/SERVICE/MLR)
365

FREEZER CHEST

Model No.
FCCS151FW

Copyright © 2006 Electrolux Home Products, Inc.
All rights reserved.

DOOR

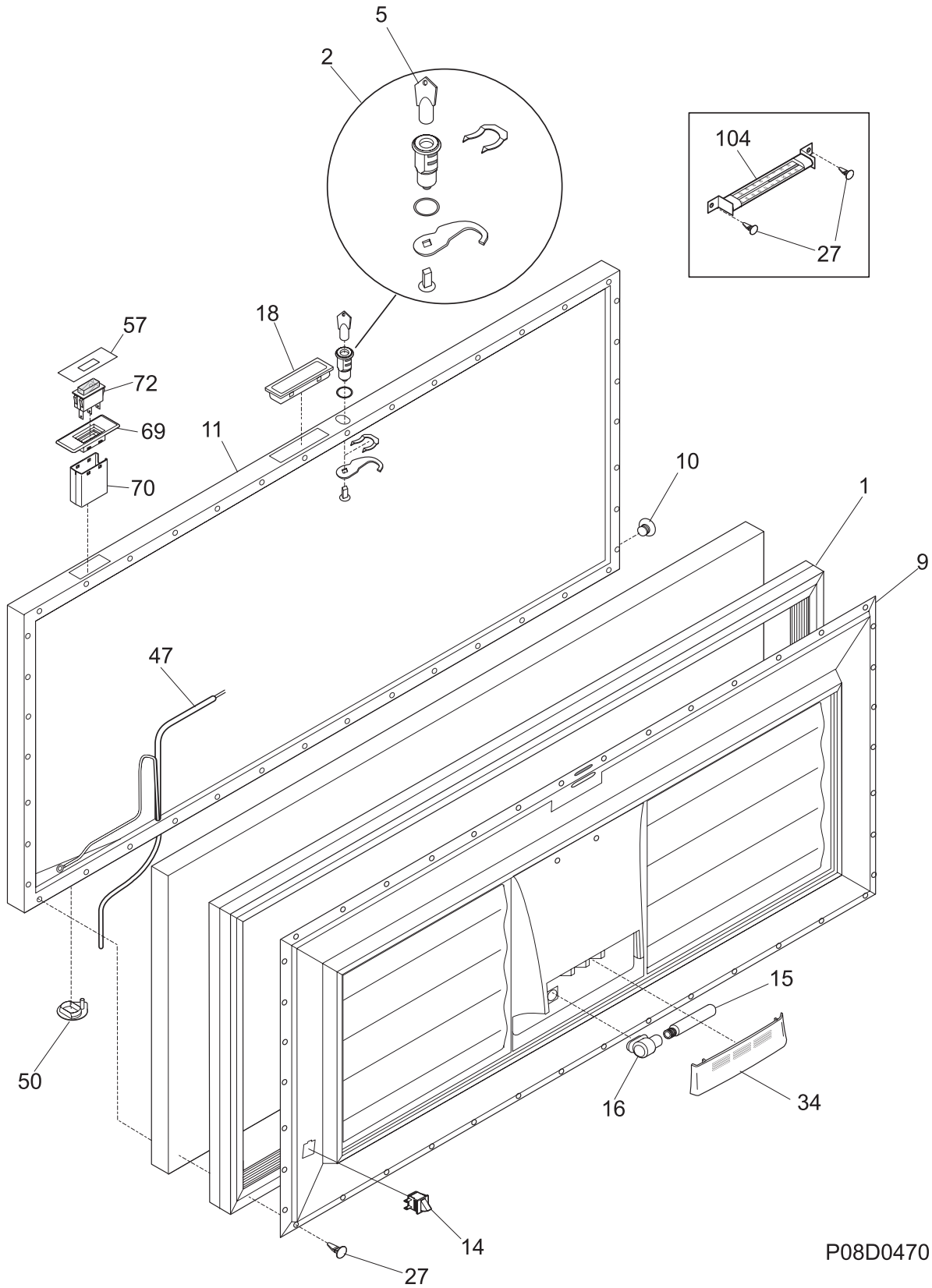

P08D0470

DOOR

POS. NO	PART NO.	DESCRIPTION
1	216481201	Gasket-door, white
2	5303925107	Lock Assy
5 #	216702900	Key, lock
9	216057908	Panel-inner lid
10	216923001	Plug button, 1/4", white
11	216129942	Panel-outer lid
*	216858000	Screw, TH#8-18x.500AB, #10
14	216822900	Switch, light/lamp, ramp
15	297070300	Light Bulb, 25W, 130V
16	216817600	Socket, light/lamp, 25 W
18	297034202	Handle, recessed, chrome, w/gasket
27	5303212828	Clip, panel mtg
27*	5304406520	Clip, panel mtg kit, (40)
34	216087900	Shield-light
47 #	297068900	Harness-lid
50	216855400	Cover, hinge, w/tape, , (2)
57	297069900	Overlay, max freeze
69	297069700	Bezel, switch, max freeze
70	297069800	Cap, seal, switch
72 #	297070000	Switch, rocker
104	297074200	Thermometer
*	5303917276	Insulation-door, fiberglass, (bulk)

CABINET

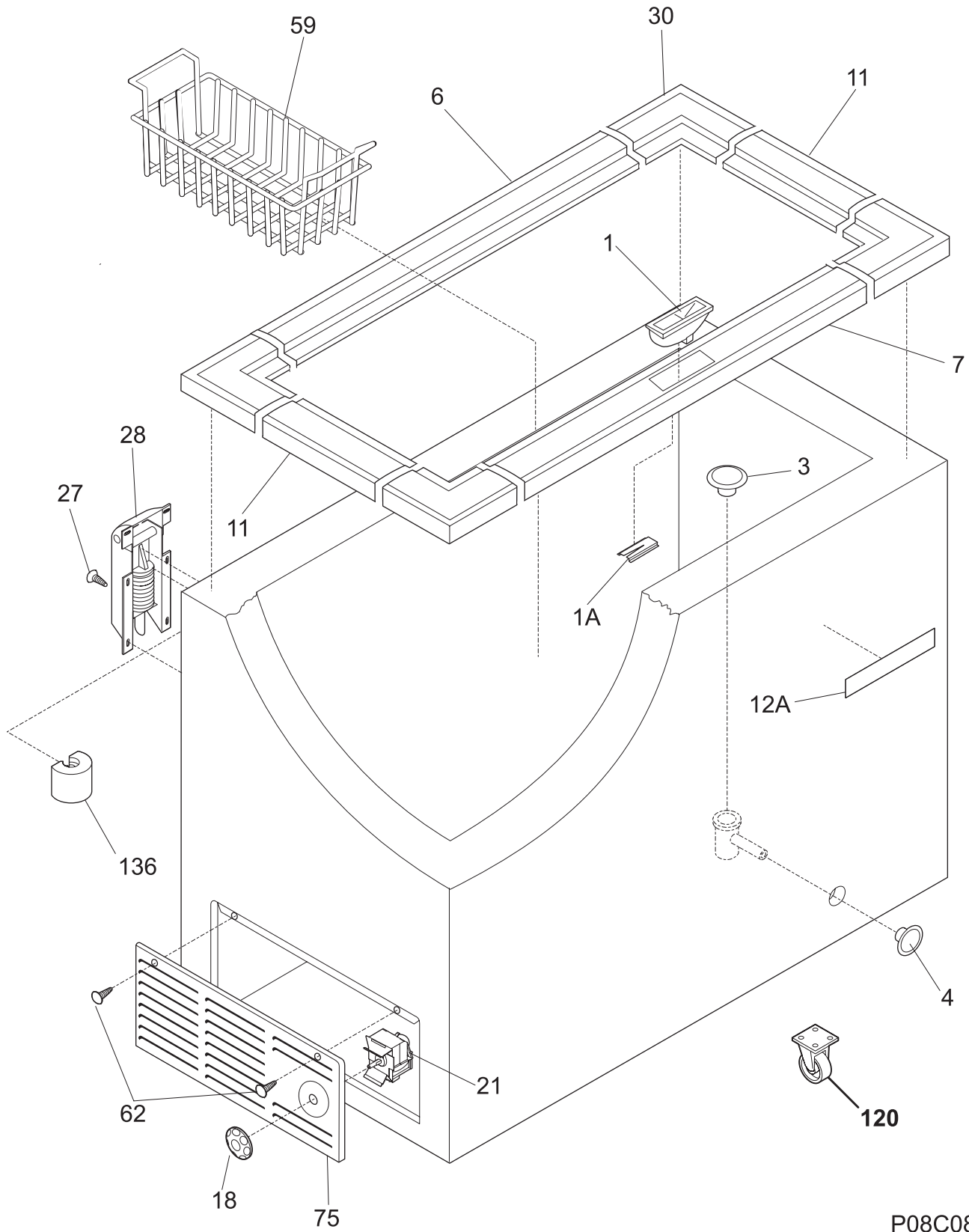

P08C0874

CABINET

POS. NO	PART NO.	DESCRIPTION
1	216909800	Catch-lock, white
1A	216818900	Support, lock catch clip
3	216502600	Plug, drain, interior
4	297013600	Plug, drain, exterior
6	216955505	Breaker, hinge side
7	216955504	Breaker, lock side
11	216955500	Breaker, chest end, (2)
12A	297073400	Nameplate, Commercial, stainless
18	216707201	Knob, temp control
21 #	216759000	Control-temperature
27	216629600	Screw, hex washer head, 10-16 x 0.500, tapping
28	216035200	Hinge
30	216110700	Breaker, corners
59	216703500	Basket, (2)
62	131420300	Screw, cr truss head, 8-18AB x 0.750
75	216034301	Panel, access, white
120	216621000	Caster
136	216726600	Guard-splash
*	216649700	CASTER PACK, 4 casters, wrench, 16 screws
*	216794214	Energy Guide
*	297001703	Insulation, 6", drain tube
*	5303305324	Paint, touch-up, white

SYSTEM

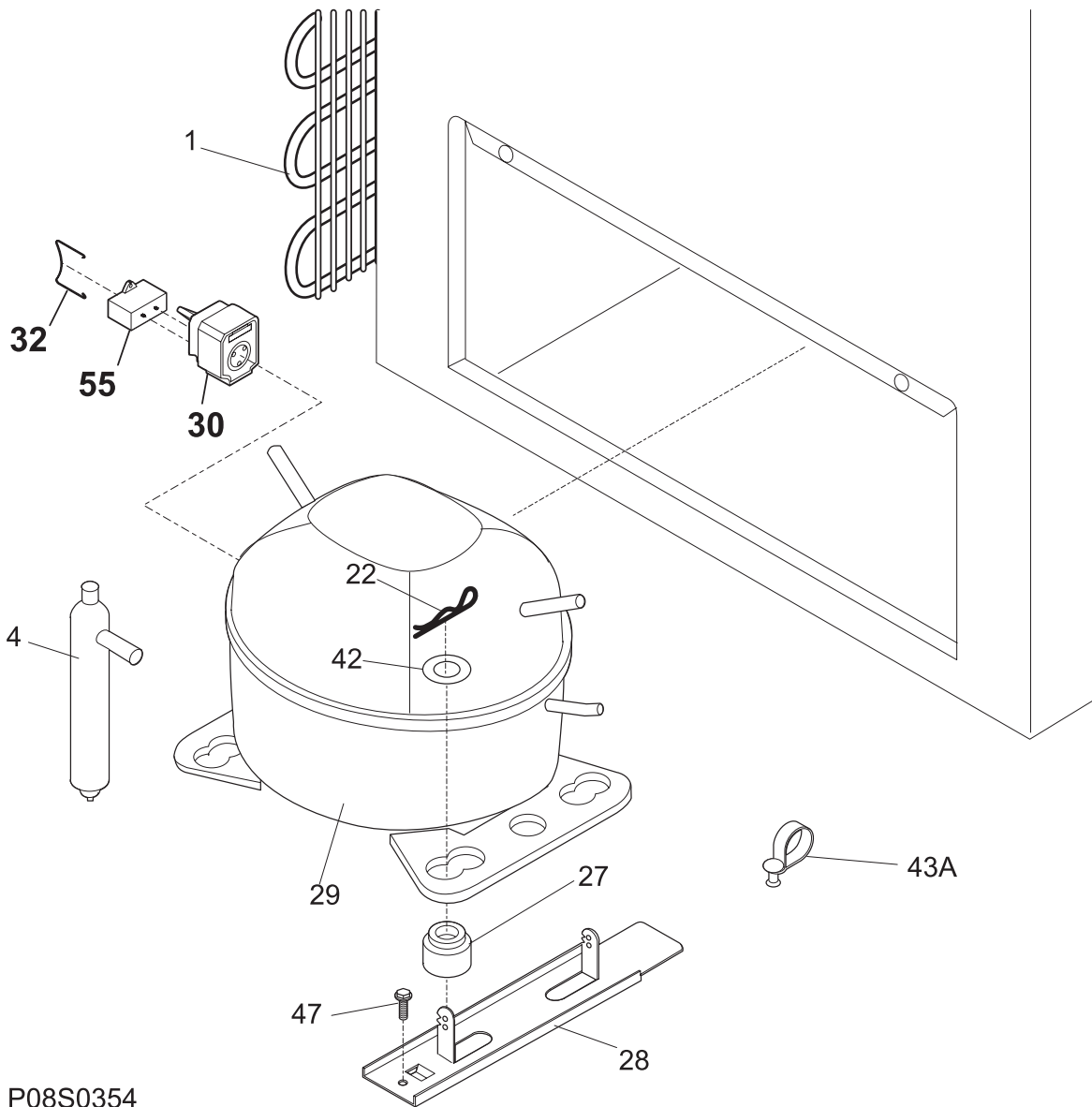
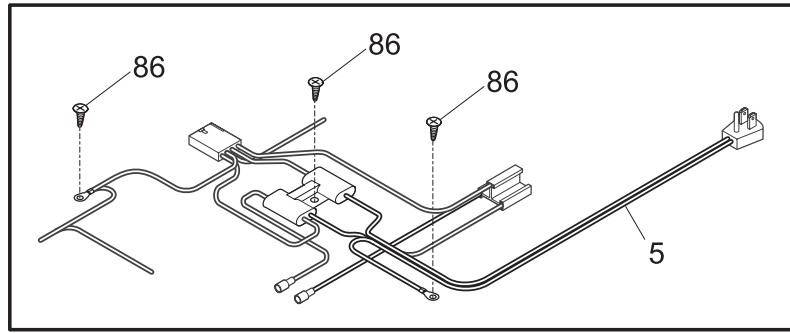

P08S0354

SYSTEM

POS. NO	PART NO.	DESCRIPTION
1	5303925238	Condenser
4 #	216938600	Drier-filter
5 #	297069100	Harness-main
22	216056400	Clip, compressor mtg, SPRING
27	5308002681	Grommet, compressor
28	5303212615	Support, compressor
29 #	297048200	Compressor, w/o electricals
30 #	297048300	Controller
32	241544101	Clamp, elec cont mtg, compressor, bale wire
42	216232700	Washer, flat, 1"OD x 0.531"ID
43A	5303212614	Clip, harness mount
47	216629600	Screw, hex washer head, 10-16 x 0.500, tapping
55 #	216236200	Capacitor-run, 180-200 VAC, 15 microfarad
86	216036600	Screw, ph washer head, 8-32CA x 0.500, thread forming
*	5303298960	Spacer-tube, 0.237" ID