

# BERTAZZONI MASTER SERIES

## DOUBLE CONVECTION SELF-CLEAN OVEN WITH ASSISTANT MASFD30XT



The Bertazzoni traditions of Italian design, engineering excellence and culinary expertise come together in the Master Series wall ovens. The exceptional, energy-efficient performance of the Bertazzoni Master Series wall ovens is enhanced by the intuitive and easy-to-use interface operated with large, round knobs and touch controls. The exclusive dual diagonal convection system and 7 usable shelf positions with telescopic glides ensure even heat roasting and baking on multiple levels with no flavor crossover. This beautiful oven installs flush with the cabinet doors and integrates seamlessly with specialty ovens and warming drawers in both vertical and horizontal combinations.

### BERTAZZONI ASSISTANT



The exclusive ASSISTANT function pilots the oven through the most appropriate sequence of cooking modes for each type of food and oven preparation. Select the sequences that best suit your own style of cooking, store them for future use and build your own bank of cooking methods.

### DUAL DIAGONAL CONVECTION

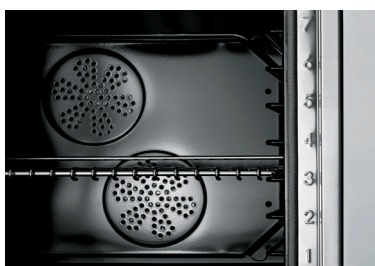

Two large-blade fans positioned on the diagonal axis and subsidiary air vents at the top and bottom of the oven cavity provide balanced airflow and even heat distribution.

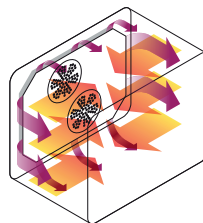

### INTEGRATED DESIGN



All Bertazzoni ovens install flush with the cabinet doors and integrate seamlessly with specialty ovens and warming drawers in both vertical and horizontal combinations.



TO COOK BEAUTIFULLY

# BERTAZZONI MASTER SERIES

## DOUBLE CONVECTION SELF-CLEAN OVEN WITH ASSISTANT MASFD30XT

### FUNCTIONS



### FEATURES

<b>Oven type</b>	electric convection self-clean
<b>Oven broiler type</b>	electric
<b>Oven controls</b>	hi-resolution LCD touch interface
<b>Inner oven door</b>	quadruple glass
<b>Auto cooking modes</b>	33 preset cooking sequences with Bertazzoni Assistant
<b>Door Hinge</b>	soft motion
<b>Oven handle</b>	solid metal
<b>Probe</b>	yes
<b>Oven door finishing</b>	stainless steel
<b>Convection System</b>	dual diagonal
<b>Oven levels</b>	7
<b>Glide shelves</b>	full extension
<b>Wire shelves</b>	2 heavy gauge
<b>Tray</b>	1 baking tray
<b>Grill trivet for Trays</b>	yes

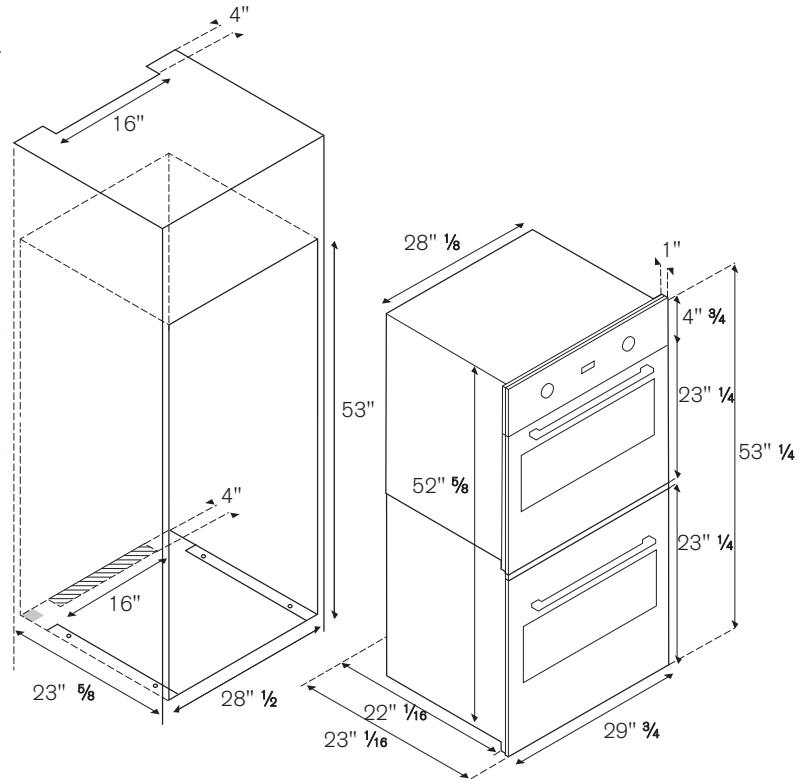

### ACCESSORIES

**30 Telescopic Slide Shelf**    item TG

### TECHNICAL SPECIFICATIONS

<b>Voltage, frequency</b>	120/208 Vac - 120/240 Vac, 60 Hz
<b>Oven volume</b>	4.1ft <sup>3</sup>
<b>Max Amp usage, power rating</b>	50 A - 11000 W
<b>Certification</b>	CSA
<b>Warranty</b>	2 years parts and labor

### INSTALLATION INSTRUCTIONS

Bertazzoni recommends to operate the appliance after it has been installed in a cabinet. The kitchen cabinets shall be made of materials capable of withstanding temperatures at least 117°F (65°C) above room temperature in order to avoid possible damage to the cabinets during oven usage. The appliance must be installed into cabinetry and be supported from underneath. The air intake opening at the bottom of the door must be left unobstructed. For a flush mount installation the surrounding cabinets doors should have the same thickness as the oven control panel.

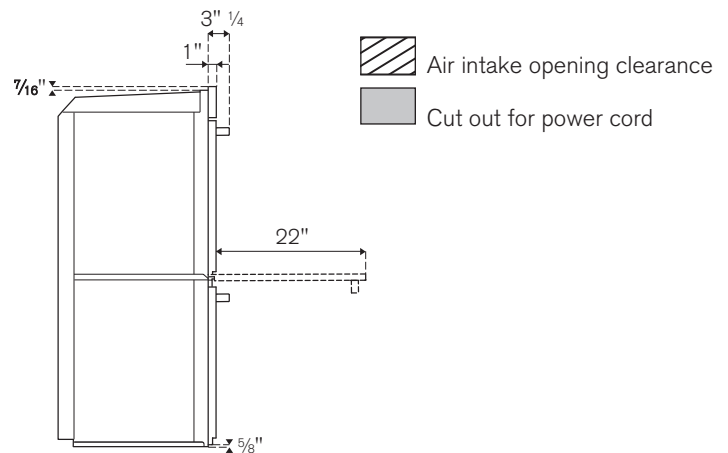

For any combinations of built-in models, please see related installation drawings

**Disclaimer:** while every effort has been made to insure the accuracy of the information contained in this brochure, Fratelli Bertazzoni reserves the right to change any part of the information at any time without notice.

Fratelli Bertazzoni, Bertazzoni and the winged wheel brand icon are registered trademarks of Bertazzoni Spa.