

# REF30PRR

REFRIGERATOR 30" BUILT-IN BOTTOM MOUNT PANEL READY  
RIGHT SWING DOOR



True flush installation with proprietary 'Lift & Swing' hinges, ensuring perfect door balance and requiring minimal clearance from adjacent cabinets

All metal construction inside and out for longer durability and optimized insulation for max cold retention

Precise temperature control for optimal food preservation: lateral airflow system, powered by dual variable-speed compressors and dual evaporators, reduces cold loss when opening door

FlexMode control to set temperature in lower compartment as Freezer (<32F), Fresco (30-34F) or Fridge (38-42F)

Automatic custom ice maker with control over ice cube size

Integrated water filter located in the low temperature section ideal for hygienically clean drinking water and ice

Digital LED touch interface with user-friendly controls for temperature, humidity, speed-freeze and ice making

## PRODUCT FEATURES

<b>Style</b>	Panel ready bottom mount
<b>Interior finish</b>	White aluminum
<b>User interface</b>	Digital LED touch interface
<b>Lighting</b>	Top and sidewall LED lights
<b>Refrigerator shelves</b>	2 full-width and height-adjustable
<b>Refrigerator crispers</b>	2 soft-close metal drawers
<b>Freezer compartment</b>	FlexMode control to set temperature as Freezer (-32F), Fresco (30-34F) or fridge (38-42F)
<b>Door storage</b>	3 height-adjustable bins
<b>Ice maker</b>	Automatic with customizable ice cube size producing up to 3 lbs/24 hr
<b>Programs</b>	Max Cool Fridge- Super-Ice - Beverage Cooler - Ice Size - Sabbath Mode Vacation Mode

## INTERIOR CAPACITY

<b>Total volume</b>	14 cu.ft
<b>Refrigerator</b>	11 cu.ft
<b>Freezer</b>	3 cu.ft

## TECHNICAL SPECIFICATIONS

<b>Voltage, Frequency, Amps</b>	115V 60 Hz - 5 Amps 550W
<b>DOE Compliant</b>	YES - 580 kWh/yr
<b>Power connection</b>	120V 3-prong plug with 98" cord
<b>Water connection</b>	1/4" waterline with accessible shut-off valve
<b>Water supply pressure</b>	Min 0.05 MPa (0.5Bar) Max 0.5 MPa (5 Bar)
<b>Certification</b>	ETL
<b>Warranty</b>	2 years parts & labor - Sealed systems: 5 years labor, 12 years parts
<b>Packaging dimensions and weight</b>	W 31 1/2" H 89" D 31 1/2" Weight 606 lbs

## ACCESSORIES

<b>901469</b>	Connection trim for side-by-side installation of panel ready built-in refrigerators
<b>Z310001</b>	Replacement water filter

# REF30PRR

REFRIGERATOR 30" BUILT-IN BOTTOM MOUNT PANEL READY  
RIGHT SWING DOOR

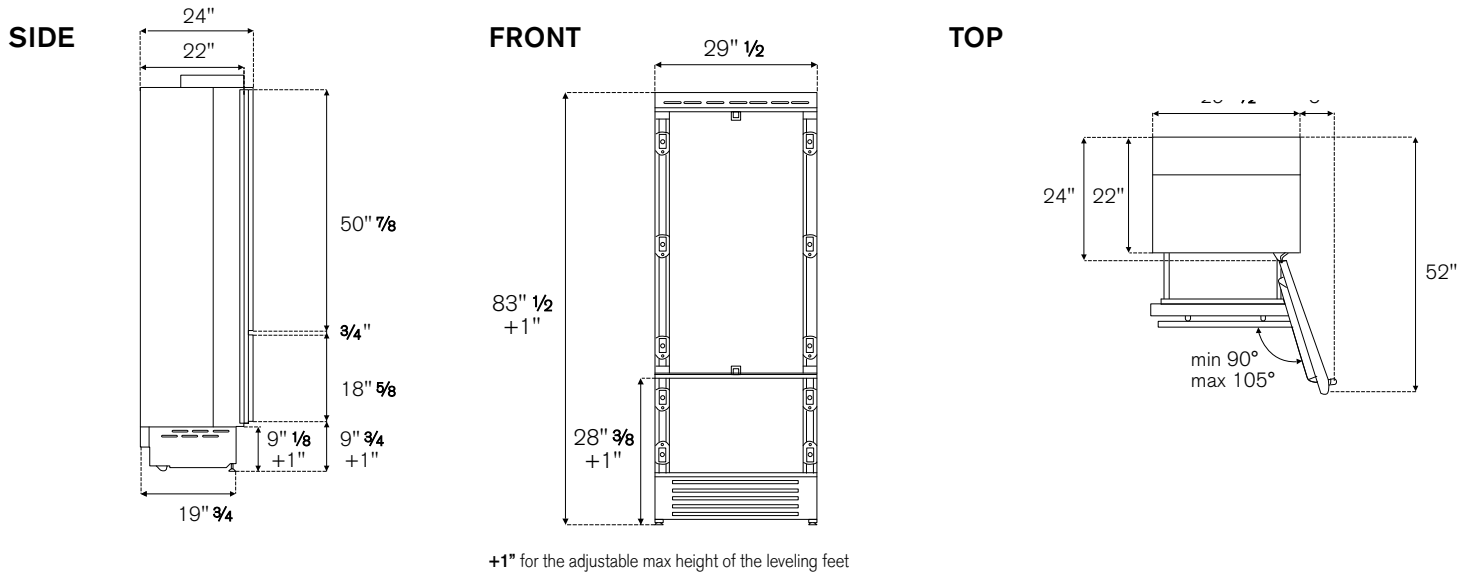

## CUTOUT DIMENSIONS

### SINGLE INSTALLATION

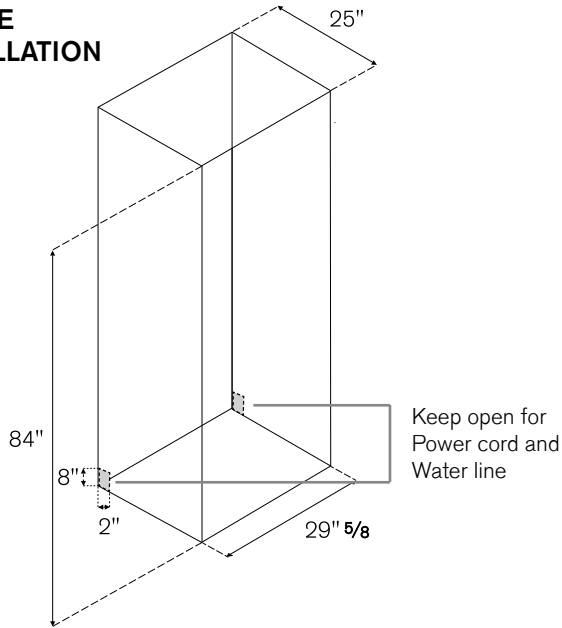

### SIDE BY SIDE INSTALLATION

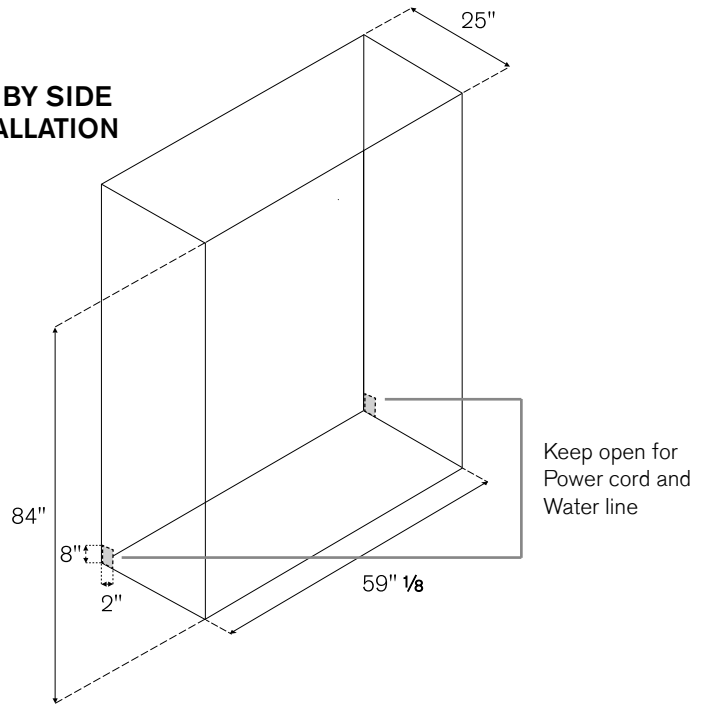

## WATER & ELECTRIC LINES:

Both lines are located at the back base of the unit. This area is 8" high and 2" deep, which allows lines to be run to their service locations. These service locations should be off to either side of the unit. Both lines are 98  $\frac{3}{8}$ " long.

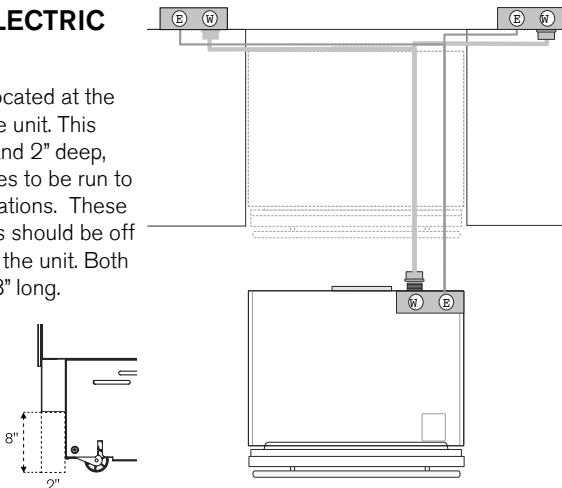

## WATER HOOKUP:

Unit comes with 1/4" to 3/4" elbow adapter. Use John Guest quick connect (push fitting) 1/4" to 3/4" metric threaded NPT. Standard GHT (Ex: stainless braided) cannot be substituted due to risk of cross threading

