BERTAZZONI PROFESSIONAL SERIES

36" COOKTOP 5 BURNER

V36 5 00 X

HIGHLIGHTS

- The soft-touch knobs and precision gas valves ensure perfect control for each burner.
- The Bertazzoni logo stands for a commitment to performance and pride of craftsmanship.
- The one-touch, child safety ignition system lets you light and adjust burners with one hand.
- The thermocouple safety system automatically stops the gas flow if the flame goes out, even when electrical power is cut.

FEATURES

Aluminum Burners	5
Wok	13000 Btu/h
Rapid	11000 Btu/h
Semi-rapid (2)	6500 Btu/h
Auxiliary	3400 Btu/h
Simmer rate	750 Btu/h
Maintop	stainless steel
Worktop control	knobs
Knobs	soft touch
Grates	cast iron
One hand ignition	yes
Wok adapter	yes
Simmer ring	yes

TECHNICAL SPECIFICATIONS

Electrical Requirements	120 V 60 Hz
Max Amp Usage	0,1 A - 10 W
Certification	CSA
Warranty	2 years parts and labor

ACCESSORIES

Simmer ring (standard)	code 408077
Stainless steel griddle (optional)	code SG36X
Wok ring (standard)	code 408117

A LP conversion kit for all burners is included



TO COOK BEAUTIFULLY
WWW.BERTAZZONI.COM

INSTALLATION INSTRUCTIONS

V36 5 00 X

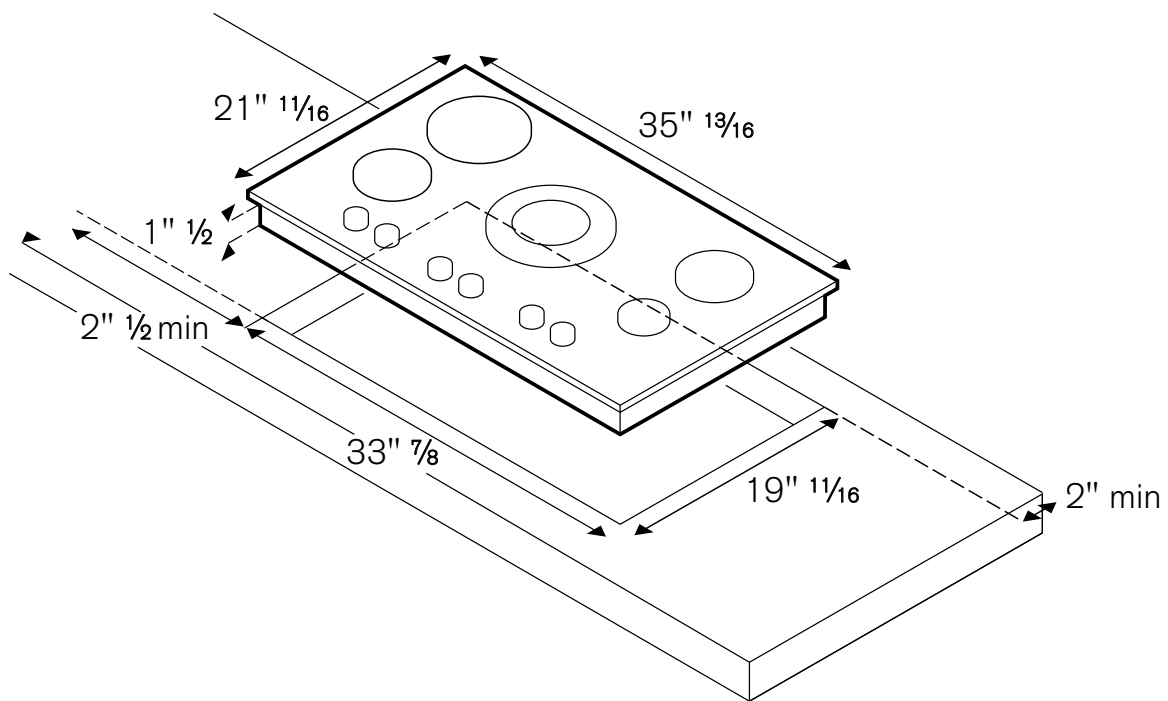

Bertazzoni recommends to operate the appliance after it has been installed in a cabinet. The kitchen cabinets shall be made of materials capable of withstanding temperatures at least 117°F (65°C) above room temperature in order to avoid possible damage to the cabinets during appliance usage. For further installation instructions refer to the installation manual.

Disclaimer: while every effort has been made to insure the accuracy of the information contained in this brochure, Fratelli Bertazzoni reserves the right to change any part of the information at any time without notice.

Fratelli Bertazzoni, Bertazzoni and the winged wheel brand icon are registered trademarks of Bertazzoni Spa.