

SFU4104MCS Available soon

linea

24" Linea Speed Oven

EAN13: 8017709265823

AESTHETIC

Linea Design

"Mystic-gray" glass finish

Full-color TFT touch screen display

TECHNICAL SPECIFICATIONS

Speed oven with 13 cooking modes

50 automatic cooking programs

Defrost programmed by weight or by time

10 customizable recipes

Electronic temperature control with touch screen

Soft-closing door

True European convection

Rapid pre-heating

"Vapor-Clean" system

"Ever-Clean" enamel cavity for quick and easy cleaning

Air-cooled, triple-glazed removable door ("Safe touch")

3 rack positions

12 5/8" size glass turntable

Time-setting functions: Delayed start, Automatic end-of-cooking, Minute minder

Automatic switch-off when door is open

2 halogen lights

Sabbath mode

Child lock

Bake element: 1,000 W

Grill element: 2,000 W

Circular heating element: 1,400 W

GENERAL SPECIFICATIONS

Oven dimensions: 18 1/16" x 23 9/16" x 22 1/2"

Oven capacity: 1.77 cu. ft.

ELECTRICAL SPECIFICATIONS

Voltage rating: 240/120 V

Frequency: 60 Hz

Nominal power: 3 kW

Current: 16 A

INCLUDED ACCESSORIES

1 x partial-extraction telescopic guide rails

1 x grid with back-stop

1 x grid for trays

1 x glass tray



Functions



SMEG U.S.A. INC.
A&D BUILDING
150 EAST 58th STREET, 7th FLOOR
NEW YORK, NY, 10155
Tel. +1 212 265 5378
Fax +1 212 265 5945

Main Oven



Microwave:

Penetrating straight into the food, microwaves cook very quickly and with considerable energy savings. Suitable for cooking without fat, they are also able to thaw and heat food without altering its original appearance and aroma. The microwave function can also be combined with conventional functions with all the resulting advantages. Ideal for all types of food.



Bake:

Ideal for slow baked cakes and casseroles. This traditional static heat will ensure food remains moist when cooked for longer periods of time.



Convection Bake:

The elements combined with the fan aim to provide more uniform heat, a similar method to conventional cooking, so pre-heat is required. Most suitable for items requiring slow cooking methods.



European convection:

Hot air fan cooking that provides quick, multi layered cooking with excellent browning results. Due to the effective circulation of hot air, there is no flavour transfer between foods. Delicate and strongly fragranced foods can be cooked at the same time.



Broil + European Convection:

Broil + European Convection



Turbo:

Facilitates the cooking of large joints, due to heat coming from all three elements. Similar to rotisserie cooking the meat is sealed, and juices are held within the joint of meat. The results are both tender and juicy.



Convection broil:

The fan reduces the fierce heat from the broiler, providing an excellent method of grilling various foods, chops, steaks, sausages etc. giving even browning and heat distribution, without drying out the food. The top two levels recommended for use, and the lower part of the oven can be used to keep items warm at the same time, an excellent facility when cooking a grilled breakfast.



Broiler:

For rapid cooking and browning of foods. Best results can be obtained by using the top shelf for small items, the lower shelves for larger ones, such as chops or sausages. For half grill heat is generated only at the centre of the element, so is ideal for smaller quantities.



Upper + microwave + fan + lower:

Fan combined with traditional cooking, where heat is generated from above and below, provides uniform heat. Adding the microwave function allows the same cooking results in less time.



Fun + circulaire + microwave:

To achieve a combined cooking with ventilated heat that cooks in short time thanks to the rotation of the warm air and the microwave.



Microwave + broil element:

To achieve a combined cooking with broil that cooks the outside whilst assuring an internal cooking thanks to the microwave function.



Reheat:

This function can reheat precooked dishes, without becoming dry or hard.

**SMEG U.S.A. INC.
A&D BUILDING
150 EAST 58th STREET, 7th FLOOR
NEW YORK, NY, 10155
Tel. +1 212 265 5378
Fax +1 212 265 5945**



SFU4104MCS

linea

microwave
24"
mystic Gray glass

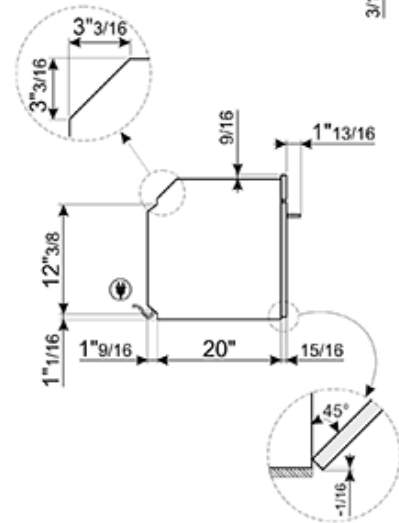
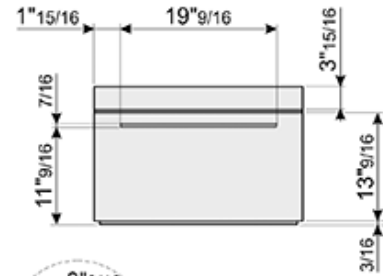
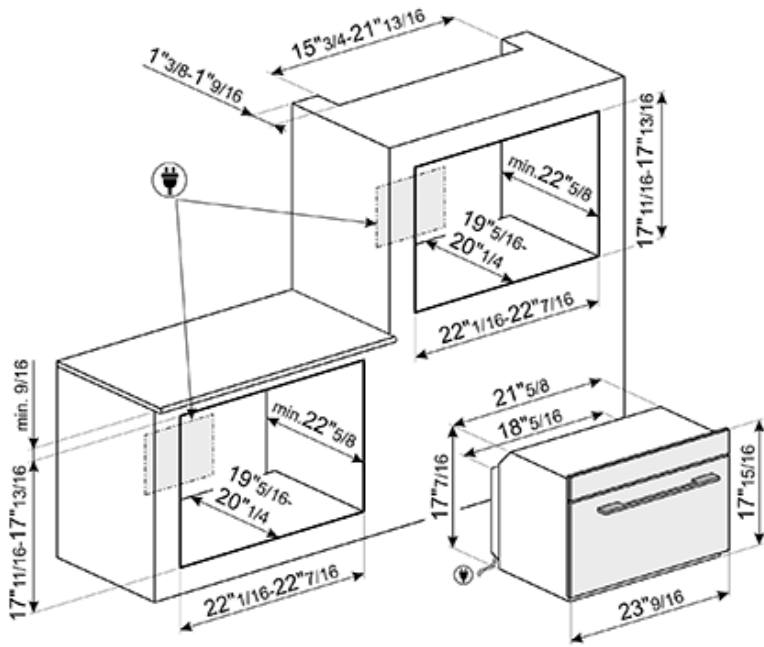

SMEG U.S.A. INC.
A&D BUILDING
150 EAST 58th STREET, 7th FLOOR
NEW YORK, NY, 10155
Tel. +1 212 265 5378
Fax +1 212 265 5945