

PRODUCT MODEL NUMBERS

WUW35X15D WUW35X24D
 WUW55X15D WUW55X24D

Electrical: A 115 Volt, 60 Hz., AC only, 15– or 20–amp fused, grounded electrical supply is required. It is recommended that a separate circuit serving only your wine cellar be provided. Use an outlet that cannot be turned off by a switch. Do not use an extension cord.

OPENING DIMENSIONS

- Height dimensions are shown with the leveling legs extended to the minimum height.
NOTE: When leveling legs are fully extended, add $\frac{5}{8}$ " (15 mm) to the height dimensions.
- If the floor of the opening is not level with the kitchen floor, shim the opening to make it level with the kitchen floor.

LOCATION REQUIREMENTS

- It is recommended that you do not install the wine cellar near an oven, radiator, or other heat source.
- Do not install in a location where the temperature will fall below 55°F (13°C). For best performance, do not install the wine cellar behind a cabinet door or block the base grille.

15" Models

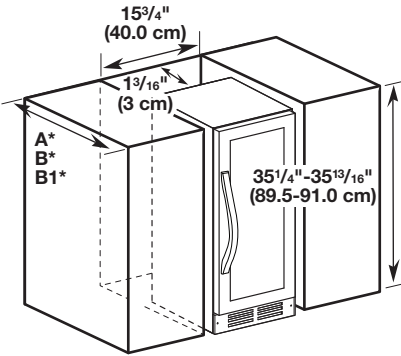

Depth Dimensions	
A*	24 $\frac{7}{8}$ " (63.2 cm) - w/o handle
B*	26 $\frac{5}{8}$ " (67.7 cm) - WUW35X15DS
B1*	26 $\frac{7}{8}$ " (68.2 cm) - WUW55X15DS

WUW35X15DS

WUW55X15DS

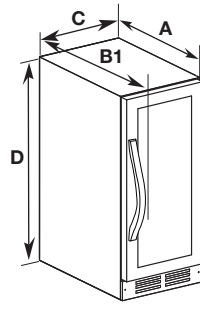
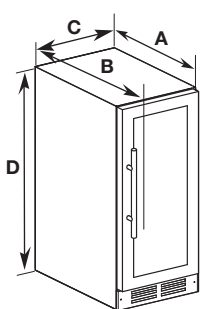

Dimensions	
A	21 $\frac{7}{8}$ " (55.5 cm)
B	25 $\frac{1}{2}$ " (64.7 cm)
B1	25 $\frac{11}{16}$ " (65.2 cm)
C	15" (38.0 cm)
D	34 $\frac{1}{16}$ " - 34 $\frac{5}{8}$ " (86.5 cm - 88.0 cm)

24" Models

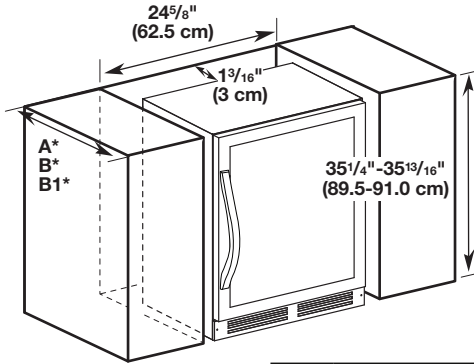

Depth Dimensions	
A*	24 $\frac{7}{8}$ " (63.2 cm) - w/o handle
B*	26 $\frac{5}{8}$ " (67.7 cm) - WUW35X24DS
B1*	26 $\frac{7}{8}$ " (68.2 cm) - WUW55X24DS

WUW35X24DS

WUW55X24DS

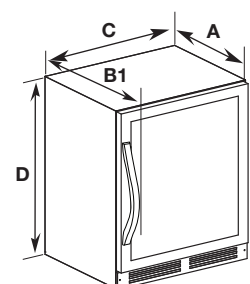
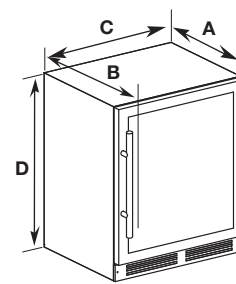

Dimensions	
A	21 $\frac{7}{8}$ " (55.5 cm)
B	25 $\frac{1}{2}$ " (64.7 cm)
B1	25 $\frac{11}{16}$ " (65.2 cm)
C	23 $\frac{13}{16}$ " (60.5 cm)
D	34 $\frac{1}{16}$ " - 34 $\frac{5}{8}$ " (86.5 cm - 88.0 cm)