

# PSB9240EF/SF/BL

## GE Profile™ Series 30 in. Single Wall Oven with Advantium® Technology

### ADVANTIUM WALL OVEN/GE PROFILE™ SERIES COOKING TOWER DIMENSIONS AND CABINET INSTALLATION INFORMATION (IN INCHES)

**NOTE:** Cabinets installed adjacent to wall ovens must have an adhesion spec of at least a 194°F temperature rating.

**NOTE:** 2" minimum between cutouts when installed above warming drawer or single wall oven.

#### INSTALLATION INFORMATION:

Before installing, consult installation instructions packed with product for current dimensional data.

**NOTE:** Advantium 240 volt models cannot be installed under 36 inches height.

**NOTE:** Use of the accessory drawer will replace the bottom trim piece for applicable installations. Please see installation instructions for full details.

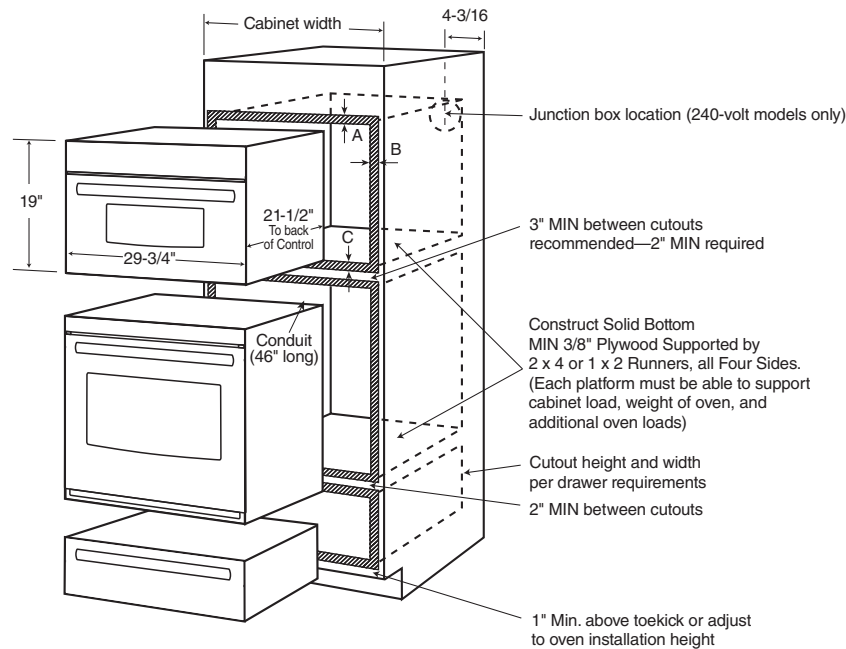

**Note:** Cabinets installed adjacent to wall ovens must have an adhesion spec of at least 194° F temperature rating.

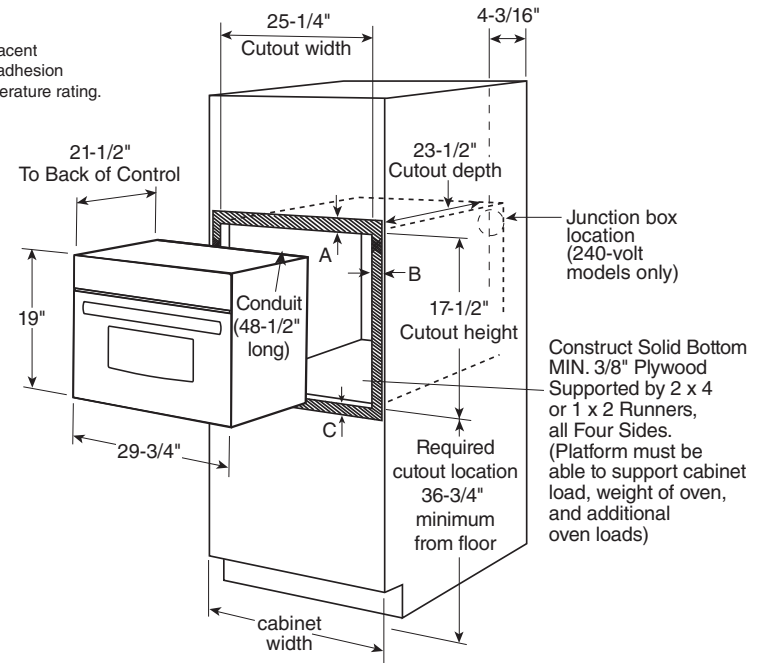

A = The unit overlap is 1/2" but allow 5/8" clearance from top edge of cutout  
 B = The unit overlap is 2-1/4" but allow 2-3/8" clearance from side edges of cutout  
 C = The unit overlap is 1" but allow 1-1/8" clearance from bottom edge of cutout

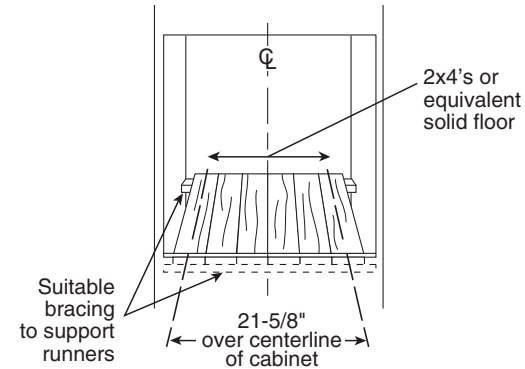

(Platform must be able to support cabinet load, weight of oven, and additional oven loads)



For answers to your Monogram, GE Cafe™, GE Profile™ or GE Appliances product questions, visit our website at [geappliances.com](http://geappliances.com) or call GE Answer Center® Service, 800.626.2000.



Specification Revised 10/20

# PSB9240EF/SF/BL

## GE Profile™ Series 30 in. Single Wall Oven with Advantium® Technology

### PREPARATION WITH AN ACCESSORY DRAWER

**PREPARE THE OPENING:** The Advantium 240V can be installed in combination with other Built-In appliances. Always follow each product's Installation Instructions to complete the installation.

**SINGLE OVEN INSTALLATION:** Order a 30" wide single oven cabinet or cut the opening in a wall to the dimensions shown.

\* For existing cutouts, a maximum width of 28-1/2" is acceptable. If the opening is slightly wider, secure a furring strip on each side of the cutout for securing the oven.

- Always maintain 36-3/4" minimum height from the floor to the cutout in any single or combined installation.

- The unit overlap on the top is 1/2" but allow 5/8" clearance from top edge of cutout. The unit overlap on each side is 2-1/4" but allow 2-3/8" clearance from side edges of cutout. The unit overlap on the bottom is 5/8" but allow 3/4" clearance from bottom edge of cutout.

- Oven overlaps will conceal cut edges on all sides of the opening.

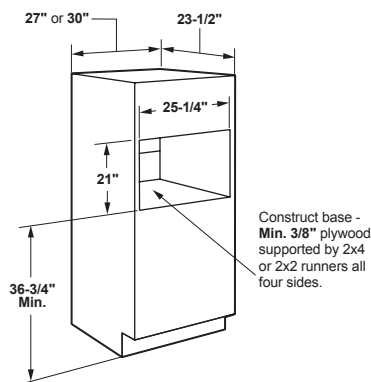

### PREPARE THE OPENING (CONT.)

When installed over a single oven or a warming drawer, allow at least 2" between the two openings. This separation will provide clearance for bottom overlap of the Advantium 240V and the other appliance overlaps.

Construct a solid oven floor of 3/8" min. thick plywood supported by 2 x 4 or 2 x 2 runners on all sides.

- The support must be level and rigidly mounted, flush with the bottom edge of the cutout.

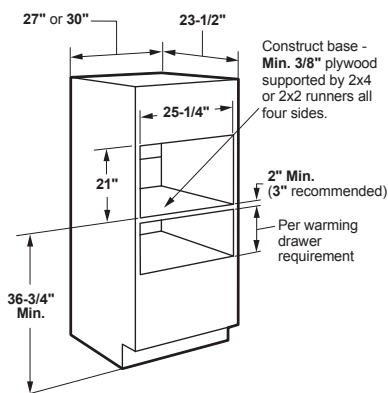

\* For existing cutouts, a maximum width of 28-1/2" is acceptable. If the opening is slightly wider, secure a furring strip on each side of the cutout for securing the oven.

**NOTE:** Additional clearances between the cutouts may be required. Check to be sure the oven supports above the Warming Drawer location do not obstruct the required interior depth and height. See Warming Drawer installation instructions for details.

### INSTALLATION OVER A BUILT-IN OVEN AND WARMING DRAWER:

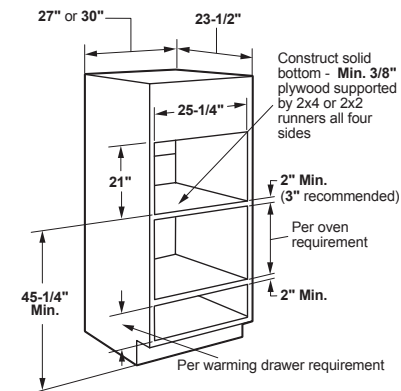

\* For existing cutouts, a maximum width of 28-1/2" is acceptable. If the opening is slightly wider, secure a furring strip on each side of the cutout for securing the oven.

**NOTE:** Additional clearances between the cutouts may be required. Check to be sure the oven supports above the Warming Drawer location do not obstruct the required interior depth and height. See Warming Drawer installation instructions for details.

**CAUTION:** For personal safety, the mounting surface must be capable of supporting the cabinet load, in addition to the added weight of the oven and drawer, plus additional oven loads.



# PSB9240EF/SF/BL

## *GE Profile™ Series 30 in. Single Wall Oven with Advantium® Technology*

### **FEATURES AND BENEFITS**

Speedcook oven (240) – Enjoy oven-quality results two to eight times faster than a conventional oven

Multiple cooking functions – Expand your cooking versatility with an all-in-one oven

Halogen heat – Skip the preheating with nearly instantaneous halogen heat

Over 175 preprogrammed menu selections - Preprogrammed selections make meals easy

Custom recipe saver – Conveniently store cooking instructions for up to 30 different recipes

Three-Speed, 300-CFM venting system

Allows for use with JX2200/2201 storage drawer (BB and SS only)

Model PSB9240EFES – Slate

Model PSB9240BLTS – Black stainless

Model PSB9240SFSS – Stainless Steel

